

Vectolub[®], Minimal Quantity Lubrication VE1B units

1-4403-US

External minimal quantity lubrication (MQL) Volumetric metering



Vectolub[®] product family, VE1B range,
with or without integrated reservoir

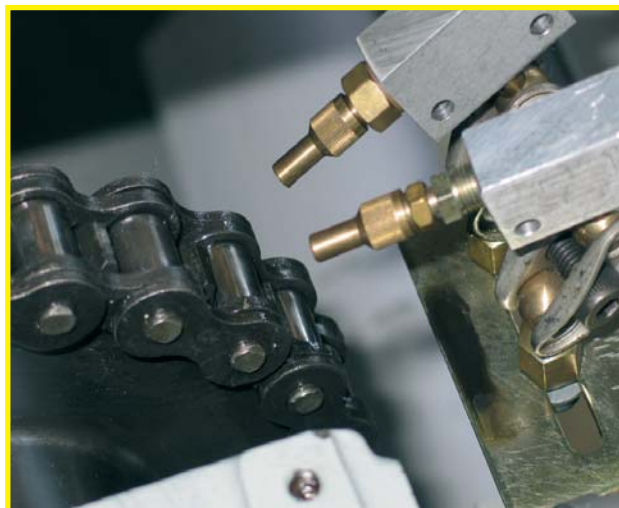

Machining, drawing, lubricant coating, chain lubrication...

Application

The eMQL system Vectolub[®] is a clean and economical alternative for lubricant projection in minimal quantity.

The Vectolub[®] system works with volumetric micropumps, which deliver very small quantities of lubricant (starting at 3 mm³) at a high frequency to the friction point by the use of a bifluid projection nozzle. This system is used for:

- Machining, drawing, sawing,
- Lubricant coating,
- Conveyors lubrication.

The **VE1B** units of the Vectolub[®] product family are compact, easy to use and economical lubrication systems. You can mount the VE1B unit directly on the machine frame by the use of standard fixing rail or a magnetic foot.

A Vectolub[®] system consists of the following components:

- the **VE1B** unit for fluid metering and delivering (air + lubricant)
- the lubricant reservoir,
- the projection nozzles and the connecting hoses.

Advantages

- Higher machining performance (higher speeds when cutting and parting).
- Better surface finish thanks to lower (friction-induced) temperature.
- Long tool life, mainly when high-frequency machining is involved.
- Exact adjustment of delivery rate saves lubricant.
- The lubricant is consumed during the machining process. No residue is left on the workpiece or chips. No disposal of lubricant residue, no degreasing of parts and chips.
- Greater safety and environmental hygiene at the workplace. No mist, clean air to breath.
- Compact unit, to be installed as close as possible to the application.
- Simple and reliable, very easy to adjust.
- All outer connections to the projection blocks are easy to release by the use of quick connectors.

Vectolub® minimal quantity lubrication, function principle

A Vectolub® minimal quantity lubrication installation consists in a VE1B unit with one or several projection blocks. These blocks are linked to the unit with coaxial lines.

The VE1B unit, fed with compressed air and lubricant, supplies every projection block with a metered volume of lubricant via the capillary tube of the coaxial line, and with a carrier air flow via the outer tube.

A low-pressure carrier air flow is swirled at the lubricant outlet zone. It breaks down the lubricant into very fine droplets, which are transported by the carrier air to the lubrication point.

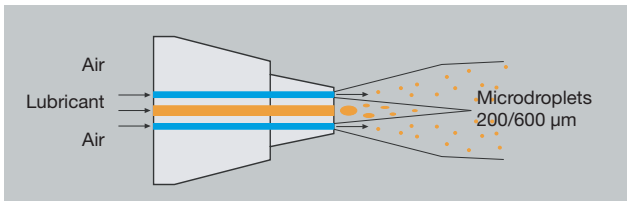

The microdroplet size (200/600 µm) ensures a perfect lubricant coating without atomization. The shape and size of the lubrication pattern are determined by the shape and dimensions of the individual nozzle openings.

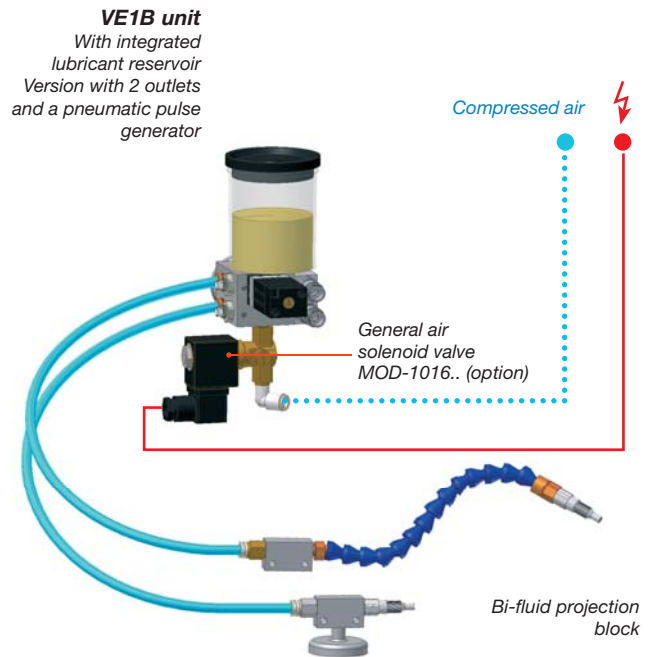

VE1B unit, function

The VE1B unit is a small and compact minimal quantity lubrication system. It comprises from one to four volumetric pneumatic micropumps, each of them feeding with lubricant one lubrication point.

The VE1B unit is fed in lubricant from an integrated reservoir, capacity 0.3 l, or from the user's external reservoir. Compressed air is also supplied to the unit from the user's network. In general the air inlet is controlled with a solenoid valve (here as option).

The compressed air flows through the ground plate of the unit and is distributed on the one hand to each micropump, and on the other hand to the coaxial outlets to be used as carrier air.

Every pneumatically actuated micropump (max. pump frequency 3 pulses/s) delivers the lubricant (starting at 3 mm³/pulse ; flow rate adjustable with thumb wheel or metering rings) through the inner capillary tube of the coaxial line into a bi-fluid projection nozzle.

The working frequency of all micropumps can be adjusted with a pneumatic pulse generator or with a solenoid valve, which is directly mounted on the unit.

Every outlet has an regulating valve to adjust the pressure of the carrier air.

Coaxial lines are connected to the outlets with quick connectors.

Installation

It is possible to fix the VE1B unit either with a magnet foot – the unit stays movable –, or with a standard fixation rail and clips.

With these solutions the unit is installed closer to the lubrication points in an area protected from any kind of projection (such as chips...), or directly installed it on the frame of the machine.







- 1 Integrated reservoir
- 2 Micropump – adjustment with thumb wheel
- 3 Pneumatic pulse generator
- 4 VE1B unit – here with 2 micropumps
- 5 Carrier air regulator
- 6 Outlet for coaxial line

VE1B unit, selection of the equipment

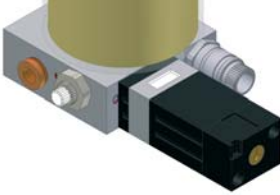
Adjustment of the working frequency – the VE1B unit shown here has only one micropump.

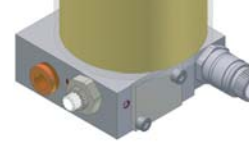
The VE1B unit can have up to four micropumps. The adjustment of the working frequency is for all micropumps.

Type P	Type E	Type O	Solenoid vale (option)
			
<p>Pneumatic pulse generator</p> <p>To adjust and control the working frequency of all the micropumps. Working frequency adjustable from 0.04 to 3 Hz.</p>	<p>Electric pulse generator (pneumatic solenoid valve)</p> <p>To adjust and control the working frequency of all the micropumps with an electronic control unit. Max. working frequency 3 Hz.</p>	<p>Simple unit without pneumatic or electric pulse generator.</p> <p>The unit has to be controlled by a general air solenoid valve located upstream the unit. See the option beside.</p>	<p>General air solenoid valve</p> <p>The solenoid valve is mounted before the VE1B unit. It controls the air supply (carrier air and actuation of the micropumps) of the unit.</p> <p>Order No. MOD-1016+ _ _ _</p>

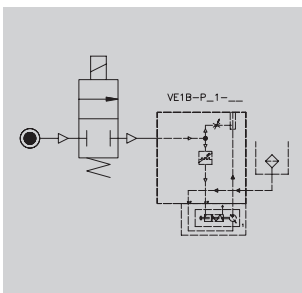
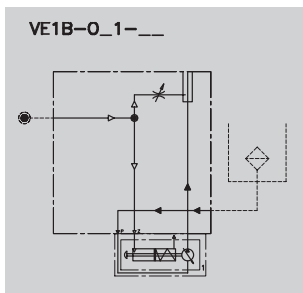
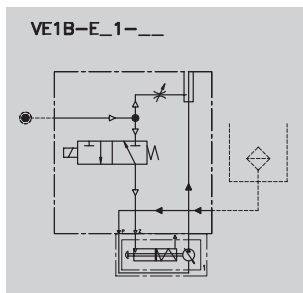
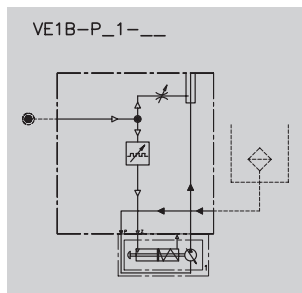

Hydropneumatic diagram of a unit with 2 micropumps, adjustment of the frequency with a pneumatic pulse generator

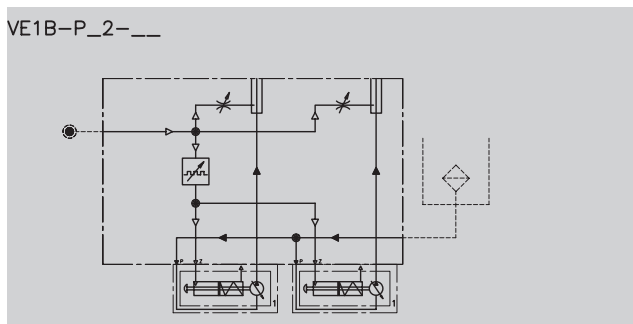

Hydropneumatic diagram of a unit with 3 micropumps, adjustment of the frequency with a pneumatic pulse generator

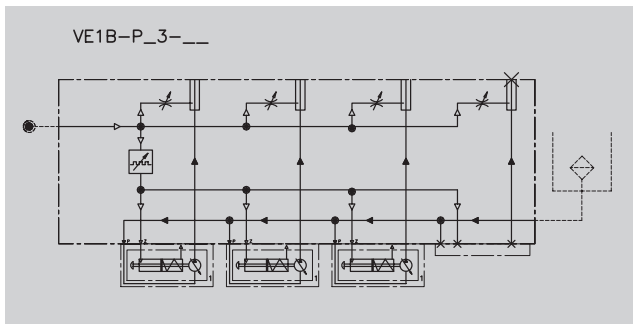

The heart of the system, the volumetric micropump

The flow range

Two flow ranges are available:

- small flow:
 - 3 to 30 mm³/stroke (metering ring),
 - small flow: 7 to 30 mm³/stroke (thumb wheel),
- large flow: 30 to 90 mm³/stroke (metering ring or thumb wheel)

The flow rate is given in mm³ for one piston stroke, and the final lubricant outflow, which is necessary for the application, depends on the micropump working frequency.

Le mode de réglage

- thumb wheel: for the small flow micropumps, a thumb wheel turn corresponds to a change of the outflow of 5 mm³/stroke, for the large flow micropumps to 15 mm³/stroke. It is possible to jam the outflow and a minimal flow is guaranteed with at least 1 1/2 thumb wheel turns (small flow) and 2 complete wheel turns (large flow).
- metering rings: for the small flow micropumps there are 6 metering rings (0/3/5/10/15/20) and for the large flow micropumps there are 4 metering rings (0/30/45/60). To get the maximal flow rate, the user puts no metering ring.

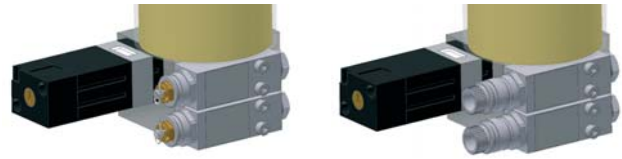

Adjustment with metering ring

Adjustment with thumb wheel

Adjustment	Version			
	3/7 to 30 mm ³ /stroke		30 to 90 mm ³ /stroke	
	Brass	Stainless	Brass	Stainless
Metering ring	A	C	E	G
Thumb wheel	B	D	F	H

Function principle

- 1 Lubricant outlet
- 2 Lubricant inlet
- 3 Air inlet
- 4 Metering ring
- 5 Check valve
- 6 Lubricant metering chamber
- 7 Hydraulic piston
- 8 Spring
- 9 Air metering chamber
- 10 Pneumatic piston

1 / Air is fed up under pressure via the air channel (3). It fills the air chamber (9) and pushes the control piston (10).

2 / The metering ring (4) limits the control piston (10) stroke. As the metering piston (7) is mechanically linked to the control piston (10) it compresses the lubricant inside the chamber (6). The valve (5) opens and the lubricant is pushed out the chamber (6) to the outlet (1).

3 / The chamber (9) is not any longer under pressure till the air inlet is shut off. The return spring (8) presses back the pistons (10) and (7) to their initial position. Then the chamber (6) is filled up with lubricant by gravity, which is delivered from the lubricant inlet (2).

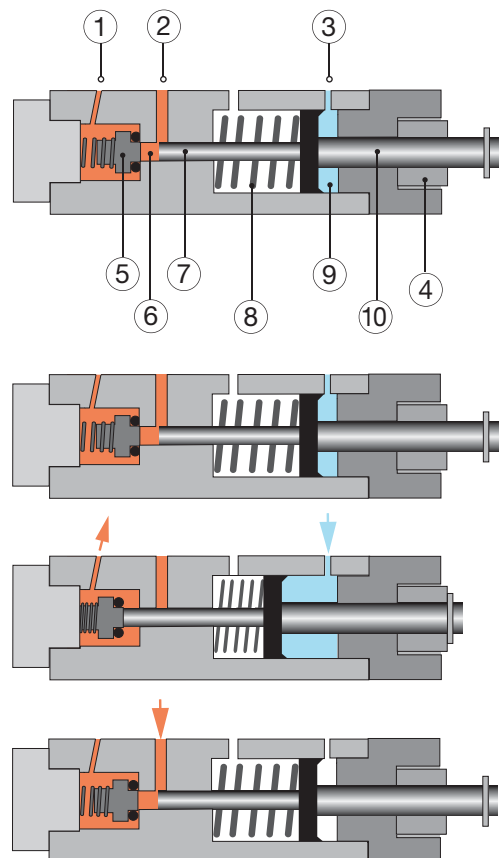

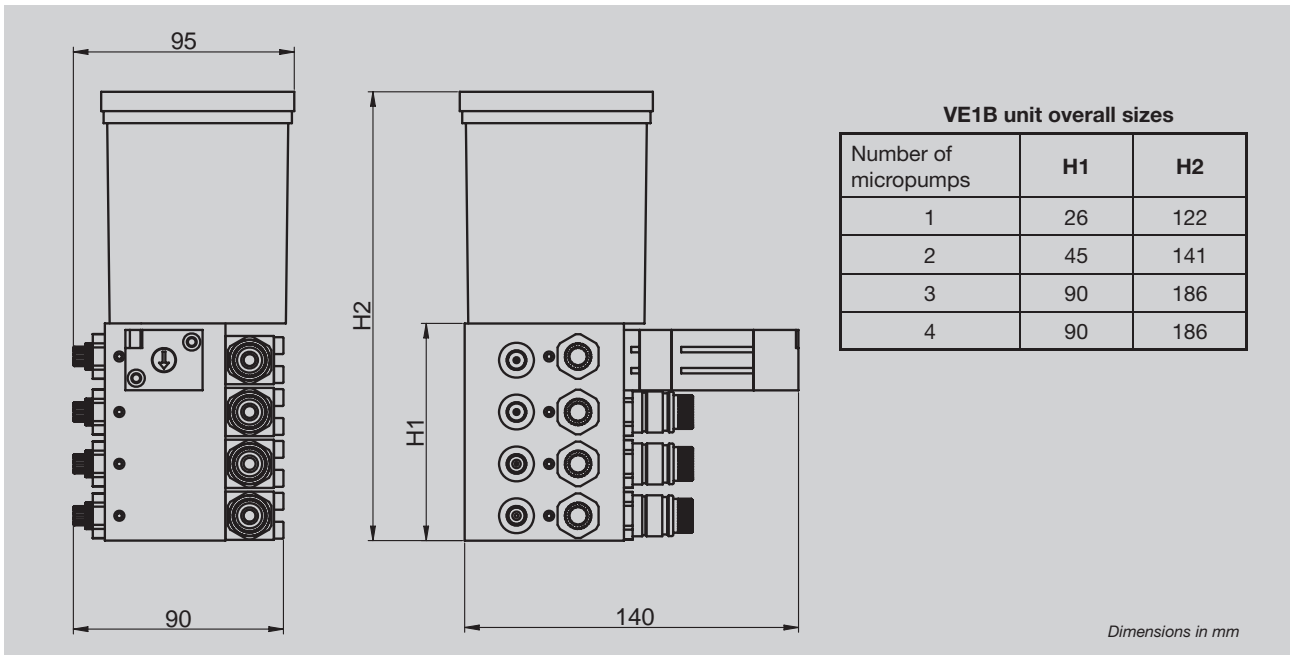

VE1B unit, connections

Hydraulic connection

If there is no integrated reservoir, lubricant is supplied from an outer reservoir*, located above the VE1B unit, inlet port G 1/4, max. inlet pressure 0.5 bar.

Option: quick connector for tube OD 8, order no. RC.802.

*) For other reservoirs, please see the leaflet 1-4402-US

Pneumatic connection

Compressed air network to supply the VE1B unit with carrier air and control air for the micropump, inlet port G 1/4.

Option: quick connector for tube OD 8, order no. RC.803.N.

Electric connection

- 115 V AC 50/60 Hz + 429
- 230 V AC 50/60 Hz + 428
- 24 V DC + 924

Outlets towards the lubrication points

Coaxial outlets (carrier air + lubricant), connection with quick connectors, coaxial lines to the bifluid projection nozzles.

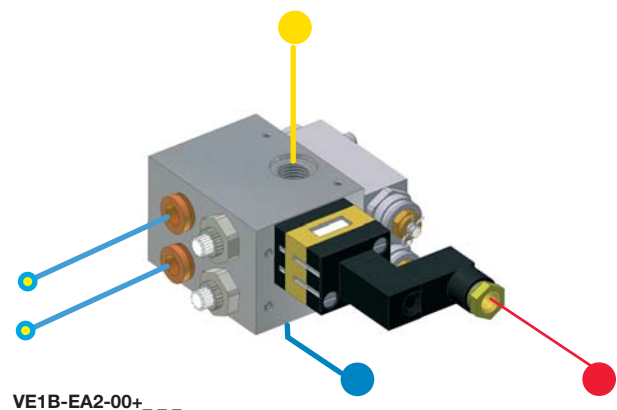
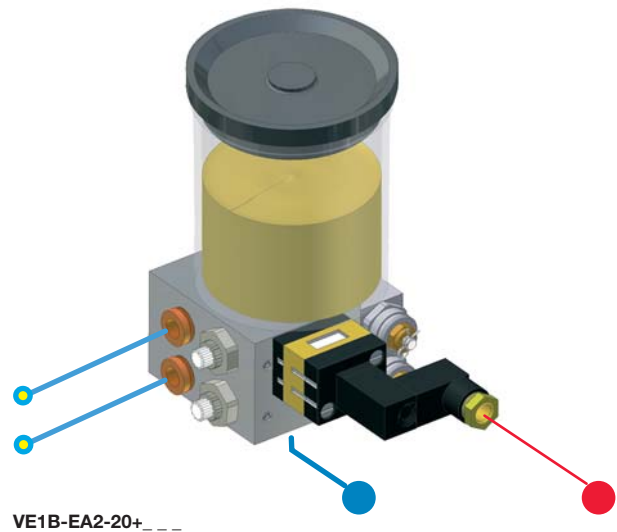

Note: The VE1B units are delivered with quick connectors for the outlets and a special tool to dismantle the coaxial lines.

Technical data VE1B

General

Number of outlets	1 to 4
Air inlet min.	400 NI/min dry and filtered air (5 µm)
Air inlet pressure	5 to 8 bars
Micropump delivery rate	
Setting with metering rings (small)	3 to 30 mm ³ / stroke
Setting with metering rings (large)	30 à 90 mm ³ / coup
Setting with thumb wheel (small)	7 à 30 mm ³ / coup
Setting with thumb wheel (large)	30 à 90 mm ³ / coup
Max. pump working frequency	3 strokes/s
Lubricant	mineral or synthetic oil, biodegradable oil
Eff. viscosity (operating temperature)	10 to 400 mm ² /s
Operating temperature	+10 °C to +50 °C
Max. weight (with reservoir and options)	1.5 kg

Air solenoid valve, type E

Delivery rate (at 6 bars)	150 NI/min
Power supply	
+ 428	230 V AC - 50/60 Hz - 2.5 W
+ 429	115 V AC - 50/60 Hz - 2.5 W
+ 924	24 V DC - 1 W
Protection	IP 65
Interface	logic element
Mechanical life	1.5 x 10 ⁷ switching operations

Pneumatic pulse generator, type P

Delivery rate (at 6 bars)	170 NI/min
Mechanical life	> 1 x 10 ⁷ switching operations
Frequency	0.04 to 3 Hz

• Recommended lubricant

The VE1B unit can deliver mineral or synthetic oil, ecological oil, with an effective viscosity between 10 and 400 mm²/s at operating temperature. Vanishing lubricants have to contain 5 to 10 % of greasy substance.

Integrated reservoir

Capacity	0.3 l
Lubricant level monitoring	
Visual monitoring	transparent reservoir

Magnetic foot (AC-3228-M)

Weight	ca. 0.5 kg
--------------	------------

Fixing rail and clips (MOD-1011)

Weight	ca. 0.3 kg
--------------	------------

General air solenoid valve (MOD-1016+__ _)

Delivery rate (at 7 bars)	430 NI/min
Power supply	
+ 428	230V AC - 50/60 Hz - 2.5 W
.....	inrush power 26 VA, holding power 14 VA
+ 429	115 V AC - 50/60 Hz - 2.5 W
.....	inrush power 26 VA, holding power 14 VA
+ 924	24 V DC - 14 W
Protection	IP 65
Mechanical life	1.5 x 10 ⁶ switching operations
Sizes	82.5 x 94 x 30 mm
Weight	ca. 0.2 kg

General air solenoid valve (MOD-1016+__ _)

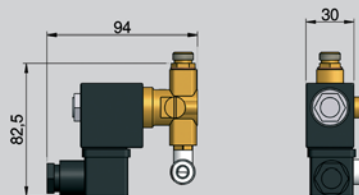

• Mode de fixation de l'unité VE1B (options)

• Rail et clips : Réf. MOD-1011

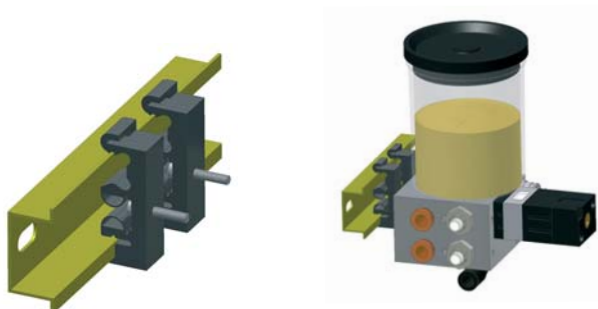

• Embase magnétique : Réf. AC-3228-M



Order information

Order No.

VE1B - _ _ - _ _ + _ _ _

Control type _____

- O = without
- P = pneumatic pulse generator
- E = air solenoid valve

Micropumps _____

- A = setting with metering rings, 3 to 30 mm³/pulse, brass
- B = setting with thumb wheel, 7 to 30 mm³/pulse, brass
- C = setting with metering rings, 3 to 30 mm³/pulse, stainless steel
- D = setting with thumb wheel, 7 to 30 mm³/pulse, stainless steel
- E = setting with metering rings, 30 to 90 mm³/pulse, brass
- F = setting with thumb wheel, 30 to 90 mm³/pulse, brass
- G = setting with metering rings, 30 to 90 mm³/pulse, stainless steel
- H = setting with thumb wheel, 30 to 90 mm³/pulse, stainless steel

Number of micropump(s) _____

1, 2, 3 or 4

Reservoir _____

- 00 = without
- 10 = with integrated reservoir 0.3 l

Voltage key* _____

- 428 = 230 V AC, 50/60Hz
- 429 = 115 V AC, 50/60Hz
- 924 = 24 V DC

*) When the air solenoid valve is selected, the voltage key has to be added to the order number

Accessories

- General air solenoid valve Order No. **MOD-1016** + _ _ _ ¹⁾

- ¹⁾ Voltage Key
- +428 = 230 V AC, 50/60 Hz
- +429 = 115 V AC, 50/60 Hz
- +924 = 24 V DC

- Fixation

- Magnetic foot Order No. **AC-3228-M**
movable fixation
- Rail and clips Order No. **MOD-1011**
permanent fixation

- Connectors for inlet G 1/4

- Lubricant inlet Order No. **RC.802**
- Air inlet Order No. **RC.803.N**

- Nozzles and coaxial line please see leaflet 1-4402-US

- Reservoirs please see leaflet 1-4402-US

For further information about the Vectolub® product range, please see the following leaflets:

- Nozzles, coaxial lines, accessories Order No. 1-4402-US
- VE1B, Operating instructions Order No. 951-130-441-US

Notice!

All products from VOGEL may be used only for their intended purpose. If operating instructions are supplied together with the products, the provisions and information therein of specific relevance to the equipment must be observed as well.

In particular, we call your attention to the fact that hazardous materials of any kind, especially the materials classified as hazardous by EC Directive 67/548/EEC, Article 2, Par. 2, may only be filled into VOGEL central lubrication systems and components and delivered and/or distributed with the same after consultation with and written approval from VOGEL.

All products manufactured by VOGEL group are not approved for use in conjunction with gases, liquefied gases, pressurized gases in solution and fluids with a vapor pressure exceeding normal atmospheric pressure (1013 mbars) by more than 0.5 bar at their maximum permissible temperature.



A brand of the SKF Group

Willy Vogel AG
 Motzener Strasse 35/37
 12277 Berlin, Germany
 PF 97 04 44 · 12704 Berlin
 Tel. +49 (0) 30-720 02-0
 Fax +49 (0) 30-720 02-111
 info@vogel-berlin.de
 www.vogelag.com

Willy Vogel AG
 2. Industriestrasse 4
 68766 Hockenheim
 Germany
 Tel. +49 (0) 62 05-27-0
 Fax +49 (0) 62 05-27-101
 info@vogel-berlin.de
 www.vogelag.com

Vogel France SAS
 Rue Robert Amy, B.P. 70130
 49404 Saumur cedex
 France
 Tel. +33 (0) 241 404 200
 Fax +33 (0) 241 404 242
 info@vogelfrance.com
 www.vogelfrance.com